

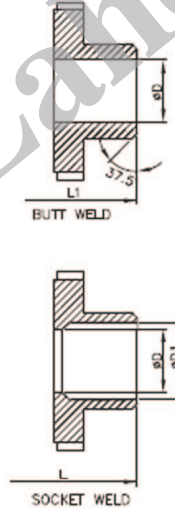

THREE PIECE TWO WAY FULL BORE 1000WOG
INDUSTRIAL BALL VALVE SCREWED END

FEATURES:

- *BLOW-OUT PROOF STEM/SOLID BALL
- *HANDLE WITH LOCKING DEVICE
- *INVESTMENT CAST STAINLESS STEEL OR CARBON STEEL
- *PIPE THREAD IN ACCORDANCE WITH B2.1 BS21 1973
DIN 259/2999 NPT
- *END CAP CF8M & CF3M (DIN 1.4403) STAINLESS STEEL
- *HIGH PERFORMANCE
- *LONG NECK ISO5211 MOUNTING PAD ENABLES TO
INSTALL ACTUATOR DIRECTLY.
- *SIZE AVAILABLE FROM 1/2"~4"

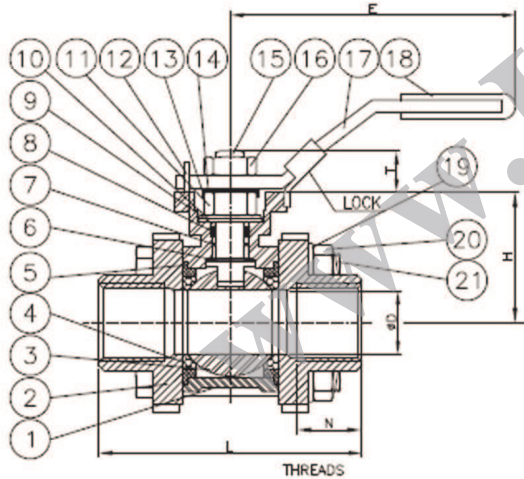
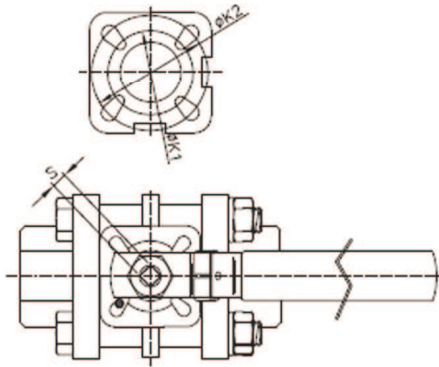

NO.	PARTS NAME	MATERIAL	Q'TY
1	BODY	AISI 316	1
2	CAP	AISI 316	1
3	BALL	AISI 316	1
4	SEAT	TEFLON	2
5	GASKET	TEFLON	2
6	THRUST WASHER	TEFLON	1
7	O-RING	VITON	1
8	STEM PACKING	TEFLON	1
9	RING	AISI 304	2~3
10	BELLEVILLE WASHER	AISI 304	1
11	STEM NUT	AISI 304	1
12	STOP PIN	AISI 304	1
13	LOCK WASHER	AISI 304	1
14	RING	AISI 304	1
15	STEM	AISI 316	1
16	HANDLE NUT	AISI 304	1
17	HANDLE	AISI 304	1
18	HANOLE SLEEVE	PLASTIC	1
19	SPRING WASHER	AISI 304	4
20	BOLT NUT	AISI 304	4.8.12
21	BOLT	AISI 304	4.6

BELLEVILLE WASHER

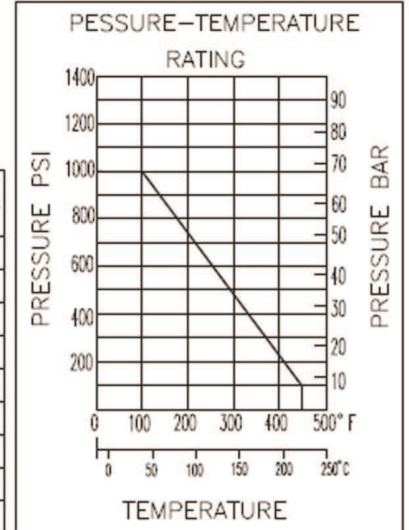

SIZE		ND	INCH	øD	L ±2	H	E ±3	T	S	øD1	L1 ±2	ISO5211		INCH/LBS	N	CV FACTOR	WT/KG
øK1	øK2																
15	1/2"	15	75	38.0	140	9	9	21.8	70	F03	F04	50	20.0	11.2	0.42		
20	3/4"	20	80	47.0	140	9	9	27.2	85	F03	F04	80	21.0	21.0	0.63		
25	1"	25	90	57.2	154	11	11	34.0	95	F04	F05	100	21.0	35.0	0.90		
32	1-1/4"	32	110	62.5	154	11	11	42.7	110	F04	F05	280	27.5	57.0	1.40		
40	1-1/2"	38	120	77.5	184	14	14	48.8	120	F05	F07	300	26.5	80.0	2.30		
50	2"	50	162	86.5	184	14	14	61.2	142	F05	F07	350	31.0	150.0	3.16		
65	2-1/2"	65	162	108.0	261	17	17	74.0	168	F07	F10	500	28.0	265.0	9.00		
80	3"	80	184	115.0	261	17	17	90.0	182	F07	F10	750	33.5	415.0	13.10		
100	4"	100	228	141.0	337	22	22	115.6	227	F10	F12	1000	41.0	780.0	22.00		